

Pro Pool-AT™ Lift



PART #: F-004PLB-AT1 (with anchor)
PART #: F-004PLBNA-AT1 (without anchor)

US PATENT NUMBER: [D507,769 S] [7,249,386 B2]
450 LB. [204 kg] MAXIMUM WEIGHT CAPACITY

MANDATORY – LEAVE THIS MANUAL WITH LIFT OWNER



Read & Follow All Instructions
Lift safety can only be ensured if the lift is installed and operated according to these instructions



NEVER permit children to play on or around the lift.
Do not allow children to use the lift without adult supervision.



NEVER apply direct water pressure to the electronics



Do not use the Pro Pool-AT™ for deck-to-waterline measurements over 9"



NEVER use the lift with a dry pool



For safety reasons, NEVER swim alone

9889 Garrymore Ln
Missoula, MT 59808
888-687-3552 | +1-406-549-0769
aquacreek.com



SAVE a copy of these instructions

Pro Pool-AT™ Lift

Table of Contents

PAGE	DESCRIPTION
3	PRO POOL-AT™ COMPONENTS
4	ADA INSTALLATION GUIDELINES
5-6	ANCHOR INSTALLATION: CORE-DRILL RETRO-FIT
7	ANCHOR INSTALLATION: SAW-CUT RETRO-FIT
8	ANCHOR INSTALLATION: NEW CONSTRUCTION
9	PRO POOL-AT™ LIFT ASSEMBLY INSTRUCTIONS
10	BATTERY MAINTENANCE
11	CARE FOR YOUR LIFT
12-13	PRO POOL-AT™ LIFT OPERATING INSTRUCTIONS
14-15	TROUBLESHOOTING GUIDE
16	PRO POOL-AT™ PARTS LIST
17	SEAT ASSEMBLY PARTS LIST
18	WARRANTY

Pro Pool-AT™ Lift

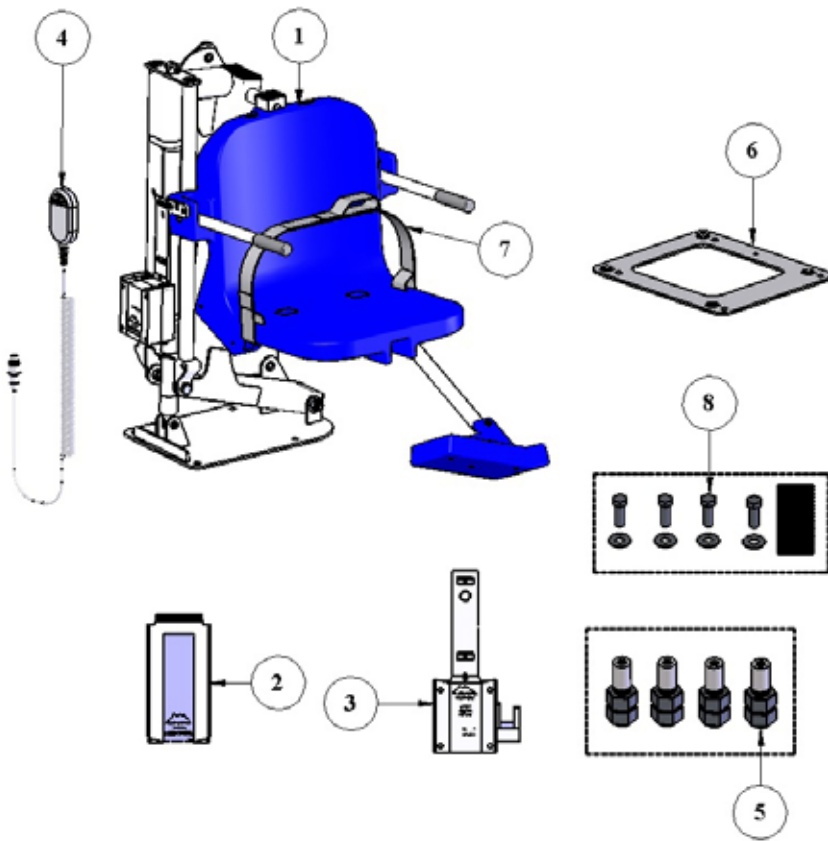

1. THE PRO POOL-AT™ POOL LIFT W/ FOOTREST
2. 24V BATTERY
3. BATTERY CHARGER W/MOUNTING PLATE & POWER CORD
4. HANDSET
5. ANCHOR INSERT BAG - SET OF 4 (IF ORDERED W/ ANCHOR)
6. ANCHOR JIG PLATE (IF ORDERED W/ ANCHOR)
7. SAFETY BELT
8. HARDWARE BAG (IF ORDERED W/ ANCHOR)

READ CAREFULLY

Check entire box and inside all packing materials for parts. Before beginning assembly, read the instructions and identify parts using the figures and parts listed in this document.

It is critical that all parts be carefully inspected by the installer prior to installation to ensure that no damage occurred in transit and that a damaged part is not used. If any damage occurred in transit, Aqua Creek Products, LLC must be notified within three days of receipt of unit.

Proper installation cannot be overstressed, as an improper installation voids Aqua Creek's warranty and may affect the safety of the user.

Installation: ADA Guidelines

ADA REQUIREMENTS:

The Pro Pool-AT™ Lift is completely ADA Compliant when installed correctly. The installation must meet the following requirements:

- Clear Deck Space Dimensions (see FIGURE 1)
- Lift installed between 14 and 19 inches from the pool edge
- Deck slope no greater than 1:48
- The seat must go at least 18" into the water. The lift should be installed at a location with 42"-48" of depth (deck to pool floor)

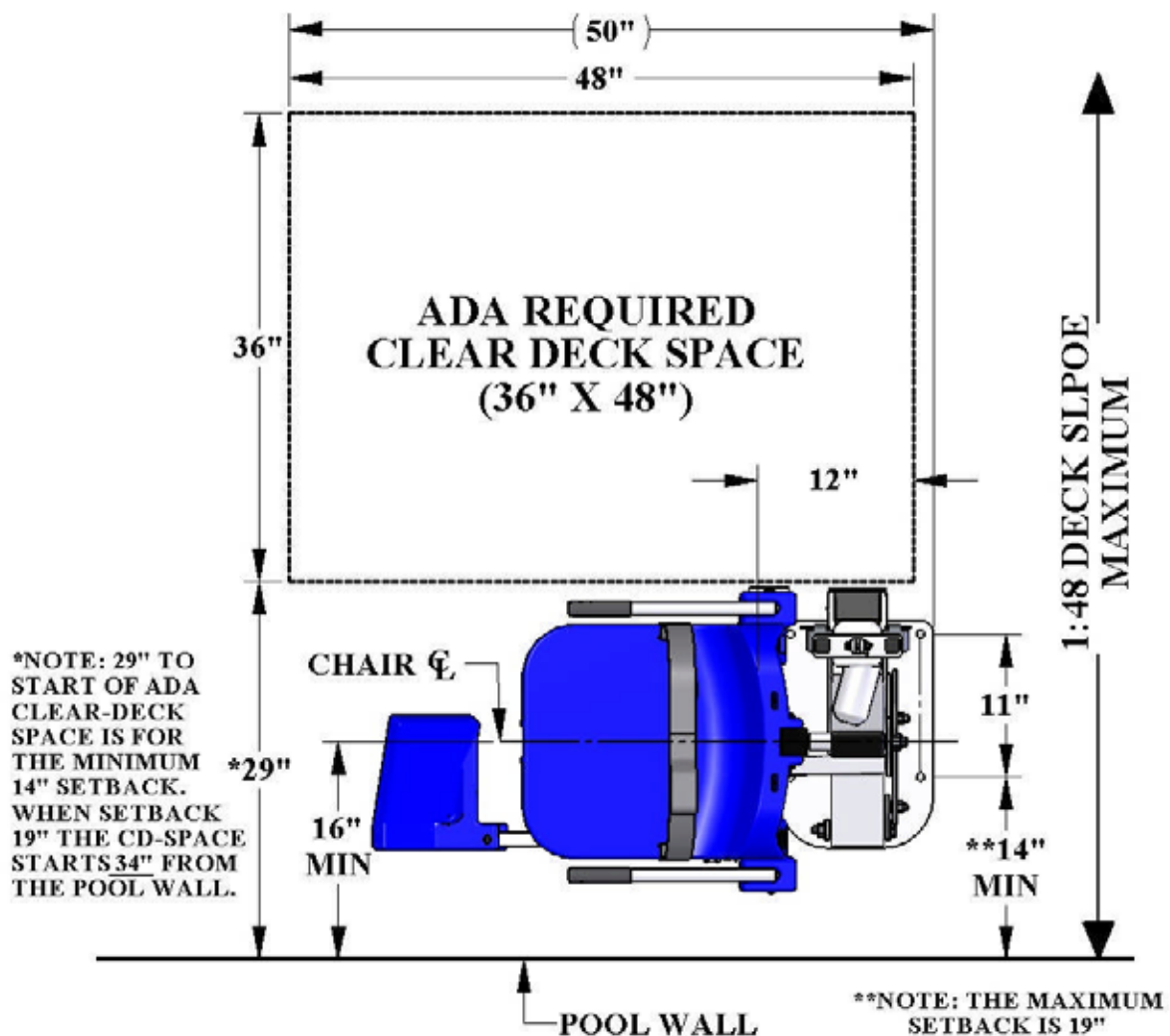

FIGURE 1

Anchor Installation: Core-drill Retro-fit

NOTE: FOR DECKS 6" THICK OR MORE, 2500PSI MINIMUM STRENGTH CONCRETE REQUIRED

You will need:

- Core drill and 1 ½" core drill bit
- Tape measure
- Marking pen
- Hammer
- Cold Chisel
- Torpedo level
- High strength 2-part construction epoxy*
- Masking Tape
- Black electrical tape (optional)

**Aqua Creek recommends either Hilti™ Brand HIT RE-500-SD or Simpson™ brand SET-XP or equivalent (not included)*



Anchor jig plate with hardware

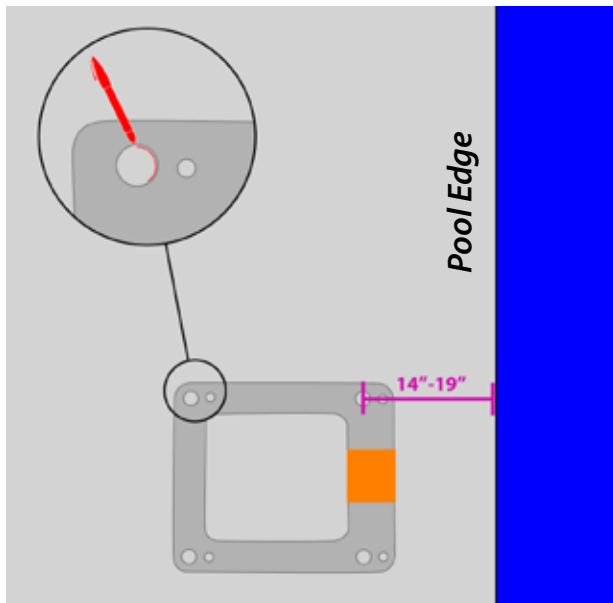

FIGURE 2

1. Mark the 4 hole locations on your deck using the larger holes of the anchor plate as a template. Make sure the center of the holes on the anchor plate are 14 to 19 inches from the pool's edge. SEE FIGURE 2

2. Drill out the 4 hole locations to about 4 ½ inch deep using the 1 ½ inch drill bit. Make sure the holes are completely dry and clear of debris.

NOTE: Create a depth marker on the drill bit with black electrical tape to make sure you drill to the right depth

NOTE: Your local bonding regulations may require that you drill one hole larger than the others in order to bond at least one of the anchor inserts. You may need to saw cut a portion of your deck.

See "Saw Cutting Retro-Fit Instructions" on page 7.

3. Remove the nuts and the black protective coverings from the threaded anchor inserts.

continued on page 6

Anchor Installation: Core-drill Retro-fit (CONTINUED)

4. Thread the mounting hardware through the smaller anchor plate holes and into the anchor inserts. Make sure to use Anti-seize on the threads! Make sure the tops of the inserts are flush with the bottom of the plate.

NOTE: We recommend using masking tape around the holes on the bottom of the anchor plate to help prevent the anchor plate from being accidentally expoxied to the pool deck.

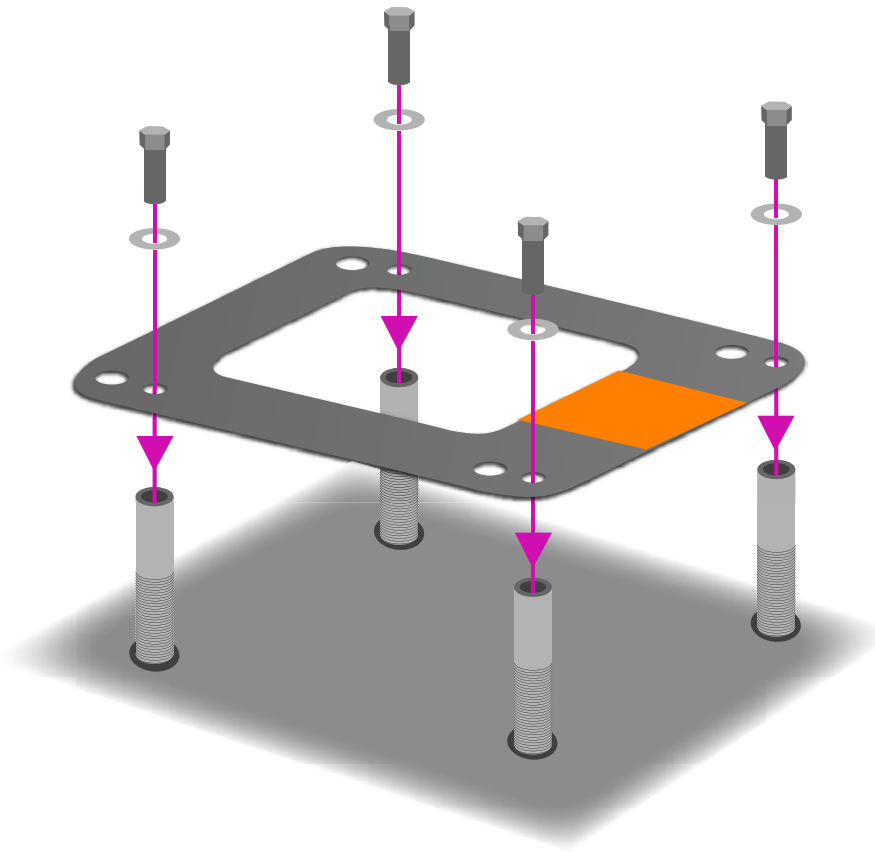

5. Bond at least one of the anchor inserts according to your local code requirements. For more information see NEC Article 680.26.

6. Test fit the anchor inserts to make sure they line up properly. Place the anchor assembly into the pre-drilled holes and use a torpedo level to check that your anchoring system will be level.

7. Remove the anchor assembly and fill each hole halfway full with 2-part construction epoxy.

8. Place the anchor assembly back into the holes. Wiggle the assembly as you reinsert it to make sure the epoxy fully coats the threads.

9. Make sure your anchor assembly is level.

10. Once the epoxy is set up, remove the hardware and the anchor plate. Your lift is now ready to be mounted to the anchoring system. The anchor plate may be recycled and/or used to install other anchors.

Anchor Installation: Saw-cut Retro-fit

You Will Need:

- Concrete saw with diamond blade
- Tape measure
- 4' long straight edge or chalk line
- Sledge hammer
- Cold chisel
- Torpedo level
- String Line
- Concrete & concrete finishing tools
- #4 rebar

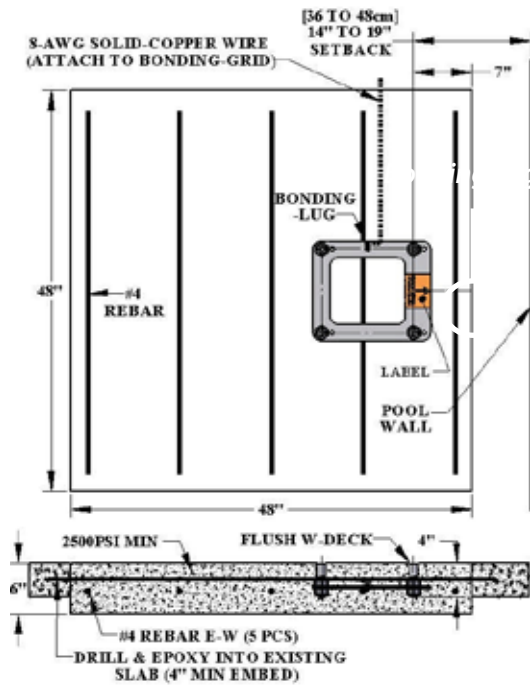

FIGURE A

1. Remove 1 nut from each anchor insert. Place the anchor inserts through the larger hole of the anchor plate. Thread the removed nuts back onto the anchor inserts. The anchor plate should be sandwiched between the two nuts on each anchor insert. *SEE FIGURE C*

2. Mark out a section of the pool deck that you are removing. Plan on removing at least 4' x 4'

3. Cut along your marks with a diamond blade concrete saw.

4. Using the sledge hammer, break up the concrete within the area you cut and remove the pieces.

6. Install rebar in the open area of the deck. Tie the rebar into the existing deck if possible. *SEE FIGURE B*

7. Set the anchor system in place. Make sure the center of the large anchor plate holes is no more than 19 inches from the pool's edge. *SEE FIGURE A*



FIGURE B

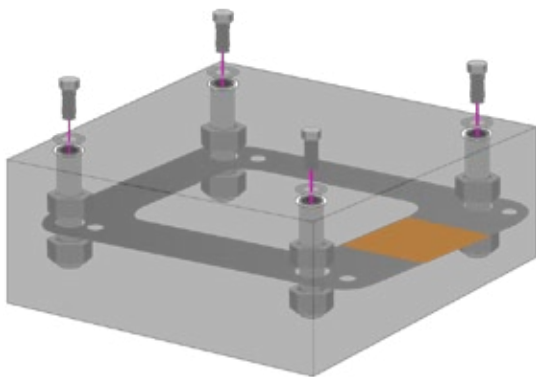

FIGURE C

8. Using the string line or a straight edge, make sure the top of each anchor body is level with the **FINISHED** deck surface. Each anchor body can be adjusted individually by turning the nuts with a large wrench.

9. Bond the anchoring system according to your local code requirements by using the bonding lug on the anchor plate. *SEE FIGURE A (See NEC Article 680.26)*

10. Pour your concrete and finish the pool deck surface. *SEE FIGURE C*

11. Once the concrete has cured, your lift is ready to be mounted to the anchoring system. *SEE FIGURE C*

Anchor Installation: New Construction

NOTE: For installations where a new deck is being poured, or where a dedicated pad is being poured just for the pool lift, the concrete must satisfy the ADA requirements outlined on page 4 of this manual.

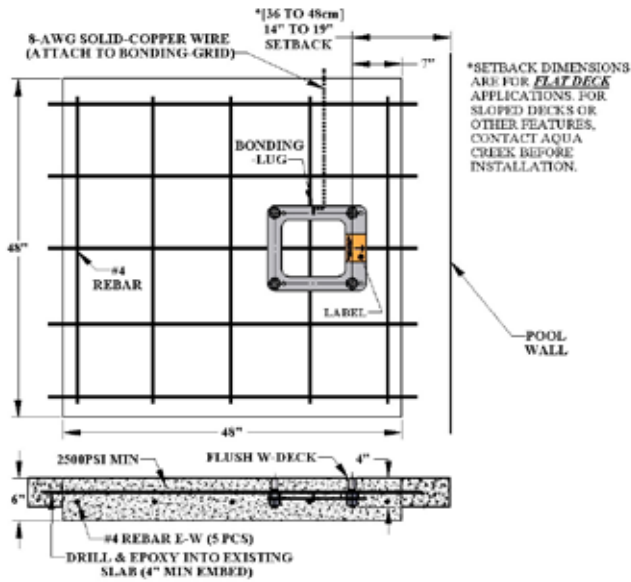

FIGURE A



FIGURE B

1. Remove 1 nut from each anchor insert. Place the anchor inserts through the larger hole of the anchor plate. Thread the removed nuts back onto the anchor inserts. The anchor plate should be sandwiched between the two nuts on each anchor insert. *SEE FIGURE C*

2. Install rebar in the open area of the deck. *SEE FIGURE B*

3. Set the anchor system in place. Make sure the center of the large anchor plate holes is no more than 19 inches from the pool's edge. *SEE FIGURE A*

4. Make sure the top of each anchor body is flush with the **FINISHED** deck surface. Each anchor body can be adjusted individually by turning the nuts with a large wrench.

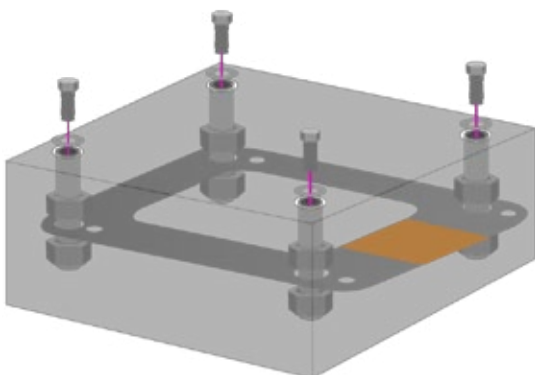

FIGURE C

5. Bond the anchoring system by using the bonding lug on the anchor plate. Bond the system according to your local code requirements. *SEE FIGURE A (See NEC Article 680.26)*

6. Pour your concrete and finish the pool deck surface. *SEE FIGURE C*

7. Once the concrete has cured, your lift is ready to be mounted to the anchoring system. *SEE FIGURE C*

Pro Pool-AT™ Assembly Instructions

1. Attach Seat belt to the seat as shown.
2. Install the Pro Pool-AT™ pool lift onto the four (4) anchors using the supplied 1/2 x 1-1/2" stainless steel hex-head bolts and 1/2" stainless steel flat washers. Make sure all bolts are tight before using the lift.



3. Apply dielectric grease to the plug terminals. Plug the handset cable to extension cord/bracket, located behind chair. Press the cord end firmly into the socket until you are sure it is all of the way into the socket. Failure to fully push the remote cord into the socket may result in faulty or interrupted operation.

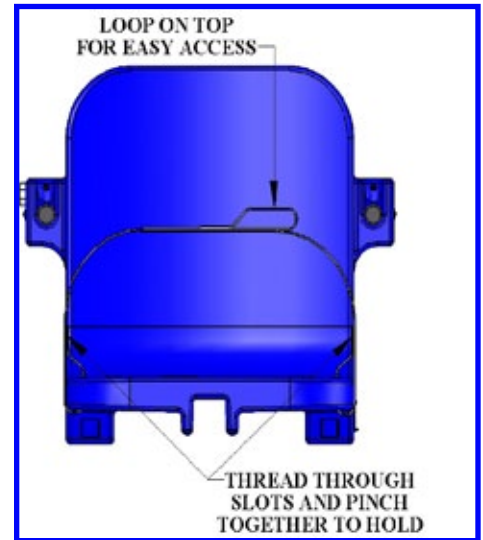

4. Before installing the battery, place it on the charging unit and let it charge for 24 hours. Make sure the orange "charge" light illuminates when the battery is being charged.

5. Remove the fully-charged battery from the charger, grease the terminals, and install it on top of the Control Box. The battery will line up square with the control box, and will 'click' when it locks in place properly. The lift will only operate when the battery is mounted properly.

WHEN NOT IN USE STORE THE BATTERY ON THE CHARGER. DO NOT LEAVE THE BATTERY ON THE LIFT WHEN NOT IN USE

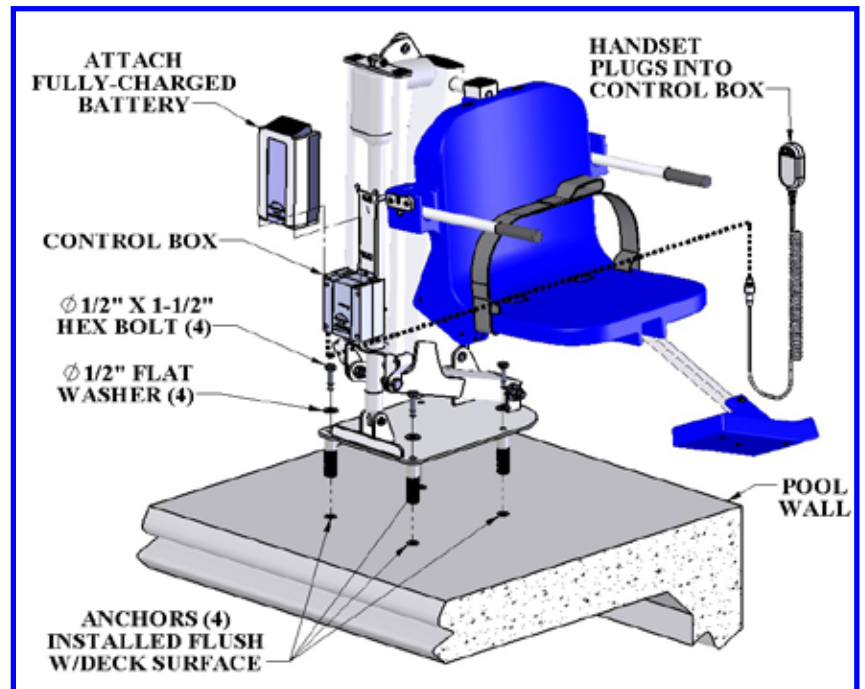

Battery Maintenance

- 1. RECHARGE THE BATTERY AS OFTEN AS POSSIBLE.** The battery power unit is a sealed lead acid battery pack. Frequent recharges will prolong the battery life and maintain a high cold amperage capacity. **THE BATTERY SHOULD BE STORED ON THE CHARGER WHEN NOT IN USE.**
- 2. Do NOT** expose the battery to freezing temperatures.
- 3. Do NOT** expose the battery to prolonged periods of extreme heat or severe cold temperatures.
- 4. Do NOT** expose the battery to long periods of direct sunlight. Heat will shorten your battery life. Optimum operating temperature is below 20 degrees Celsius (68 degrees F.)
- 5. Never** drop or bump the battery pack. This may result in loose or damaged internal connections, and may damage the battery terminals.
- 6. Keep** battery terminals clean and free from dirt and corrosion to ensure good contact. The terminals may be cleaned using Scotch Brite™ pad or any similar product. Clean off any corrosion or discoloration of the battery contacts and then apply dielectric grease (supplied with lift) as shown in the figure below.



Clean with Scotch-Brite™ pad and apply dielectric grease to terminals

Proper Care of Pool & Spa Lifts

PROCEDURE	DAILY	WEEKLY	MONTHLY
Wash down lift with fresh water and dry with clean, soft, non-abrasive cloth	✓		
Recharge battery	✓		
Run the lift through a complete test cycle to verify it is functioning properly	✓		
Visually inspect lift for damage, corrosion, and loose or missing hardware	✓		
Check all contact points for damage and/or corrosion		✓	
Repair, clean, and apply dielectric grease to all contact points		✓	
Thoroughly clean lift frame and apply a liberal coat of car wax to maintain the lift's finish			✓
Check all Warning and Cautionary labels to make sure they are not faded or worn. Replace as needed.			✓

PROPER CARE NOTES

- **Use only fresh water to wash your lift. Do not wash with pool water**
- Use only clean, soft, non-abrasive cloths to wipe down your lift
- Do not store lift in pump room or near chemicals
- Do not allow children to play on or around this lift
- When cleaning the lift do not spray water directly on control box or battery
- The lift may need to be bonded according to local code requirements

STAIN REMOVAL TIPS:

To remove stains, wash affected area with mild dish soap. For stubborn spots and stains try using soft scrub with some brisk rubbing. Use white epoxy paint to touch up. Apply wax to finish.

For service and/or replacement parts contact Aqua Creek Direct at
Toll free: (888) 687-3552

Pro Pool-AT™ Operation Instructions



Flip Up Armrests

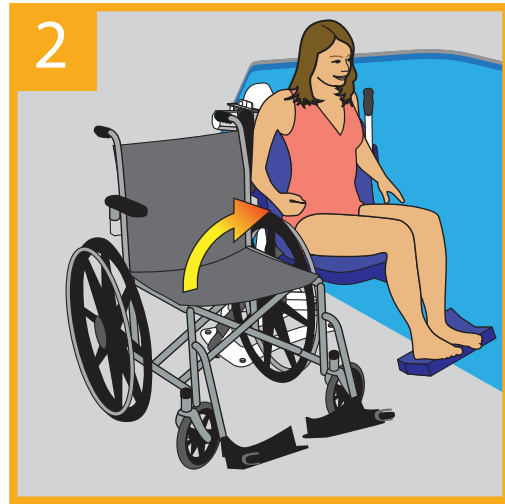

Transfer to Lift

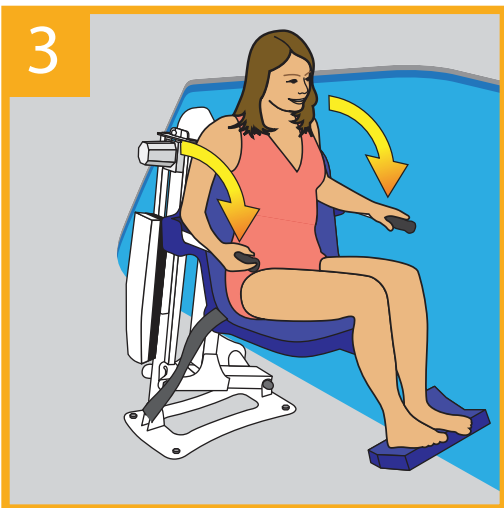

Lower Armrests

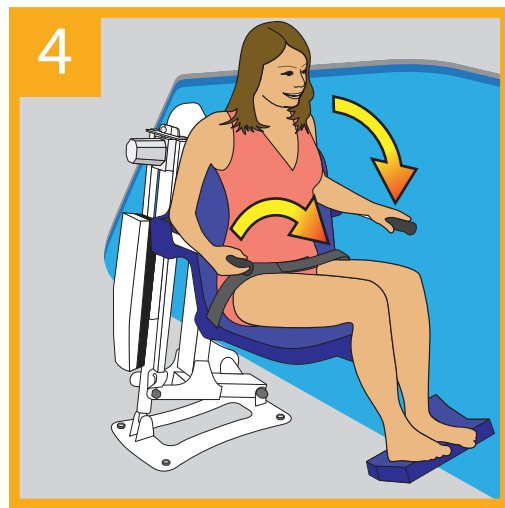

Secure Lapbelt

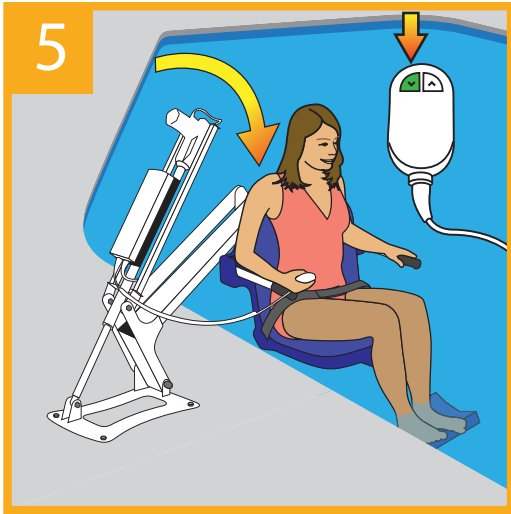

Lower Lift by Applying Pressure to the Down Arrow

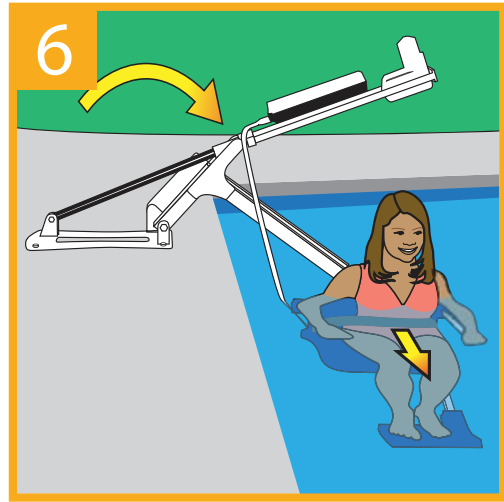

Release Pressure from Button to Stop, Then Release Lapbelt

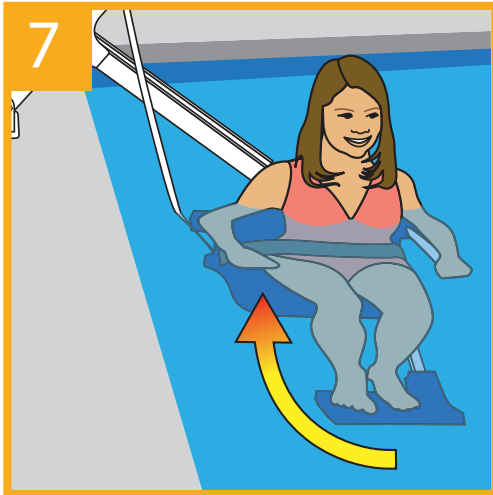

Return to Submerged Lift Seat & Secure Lapbelt

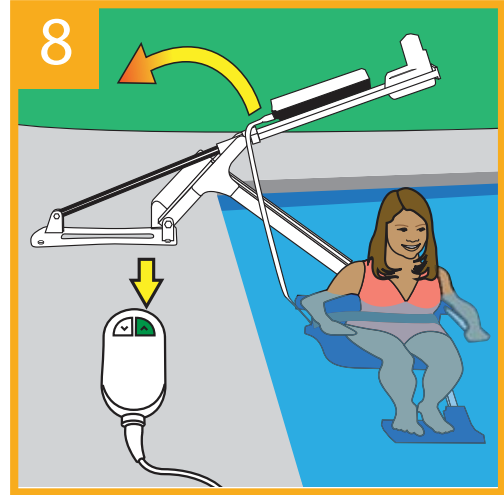

Raise Lift by Applying Pressure to the Up Arrow

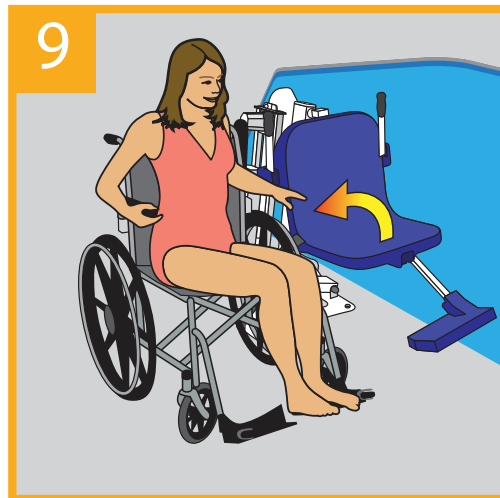

Release Lapbelt, Raise Armrests, & Exit Lift Seat

Troubleshooting Guide

Problem: The lift won't move when the handset button is pressed.

Solution:

1) Make sure the Battery is properly seated:

You should hear a click when the battery is properly seated on the control box or charger.



NOT Properly Attached:
Note the white bracket is in front of the silver clip, which will not allow for an electrical connection



Properly Attached:
Note that the white bracket is behind the silver clip, holding it securely to allow for an electrical connection

2) Make sure the cords are properly plugged in:



NOT Properly Inserted:
The cord plug is flush with or sticking out of the outlet



Properly Inserted:
The cord plug is recessed into the outlet

Check the ends of the cords for corrosion or damage. The cord plugs should be recessed into the outlet. You should feel them pop into place when they are correctly inserted.

Troubleshooting Guide (CONTINUED)

3) Check the contact points:

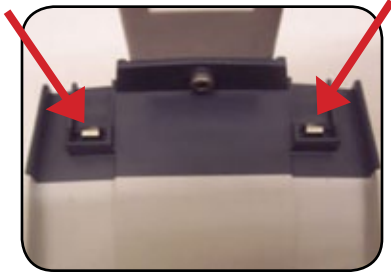

Make sure the contact points of the control box and the battery are not damaged or corroded. If there is corrosion, clean with Scotch-Brite™ pad. Put some dielectric grease on the contact points before reattaching the battery.

4) Make sure the Battery is fully charged:



The Charger is ON when the green light is glowing



The Battery is CHARGING when the orange light is glowing



When the Battery is charged, the orange light will stop glowing

Problem: The lift stopped moving over the water and is stuck.

Solution:

1) Press the Emergency button

Use a pen or pencil tip and stick it into the emergency button on the front of the control box to retract the lift.

Note that the lift will not retract if the battery is not fully charged or if the control box is not working. The emergency button only overrides the remote handset.



Pro Pool-AT™ Parts List

ITEM #	QTY	PART #	DESCRIPTION
1	1	PPB-100-10	PP-AT BASE ASSEMBLY
2	1	PPF-200-10	PP-AT MAIN FRAME ASSEMBLY
3	1	A-2012ARM-R1	PRO POOL CHAIR ARM ASSEMBLY
4	1	A-2012SRS	PRO POOL SEAT SUPPORT
5	1	L-2014FL-PAT-R2	PP-AT CONTROL ARM
6	1	A-8980PPAF-AT	PRO POOL-AT ACTUATOR ASSEMBLY
7	1	SA-0904CA-A	18" CHAIR ASSEMBLY
8	1	SA-0904FRA	FOOTREST ASSEMBLY
9	2	BOLT, 1/4 x 3/8 HWH, SS	1/4" 20 X 3/8" HEX WASHER HEAD, SS
10	1	BOLT, 5/16 x 4 HCS	5/16"-18 X 4" HEX BOLT, SS
11	3	FLATWASHER, 5/16 SS	5/16" FLATWASHER, SS
12	2	NYLOCK, 5/16 SS	5/16"-18 NYLOCK NUT, SS
13	1	BOLT, 3/8 x 1 3/4 SHOULDER	3/8" X 1-3/4" SHOULDER BOLT, SS
14	2	FLATWASHER, 1/2 SS	1/2" FLATWASHER, SS
15	2	NYLOCK, 1/2 SS	1/2"-13 NYLOCK NUT, SS
16	2	BOLT, 5/8 X 1 1/2 HCS	5/8"-11 X 1-1/2" HEX BOLT, SS
17	1	BOLT, 5/8 X 6 HCS	5/8"-11 X 6" HEX BOLT, CUSTOM
18	2	FLATWASHER, 5/8 SS	5/8" FLATWASHER, SS
19	3	NYLOCK, 5/8 SS	5/8"-11 NYLOCK NUT, SS
20	1	NYLOCK, 3/4 SS	3/4"-10 NYLOCK NUT, SS
21	2	TT-1001-1	7/8" X 1/2" X 1/8" THST WSR, BZ
22	2	MACH-BUSHING, 5/8 X 7/8 X 1/4	5/8" X 7/8" X 1/4" CUSTOM BUSHING
23	1	TT-1205-1	1-1/4 X 3/4 X 1/8 THSTWSR, BZ
24	2	FL-50-3	1/2" X 5/8" X 3/8" FLNG BRNG, BZ
25	2	FL-64-6	5/8" X 7/8" X 3/4" FLNG BRNG, BZ
26	1	MACH-BUSHING, 7/8 X 3/4 X 1/4	3/4" X 7/8" X 1/4" FLNG BRNG, BZ
27	2	FL-75-6	3/4" X 7/8" X 3/4" FLNG BRNG, BZ
28	3	SCR-1-10-14	1" SQ. BLACK PLASTIC CAP
29	3	SCR-2-10-14	2" SQ. BLACK PLASTIC CAP
30	2	RER-50X100MM	2" X 4" RECT. PLASTIC CAP

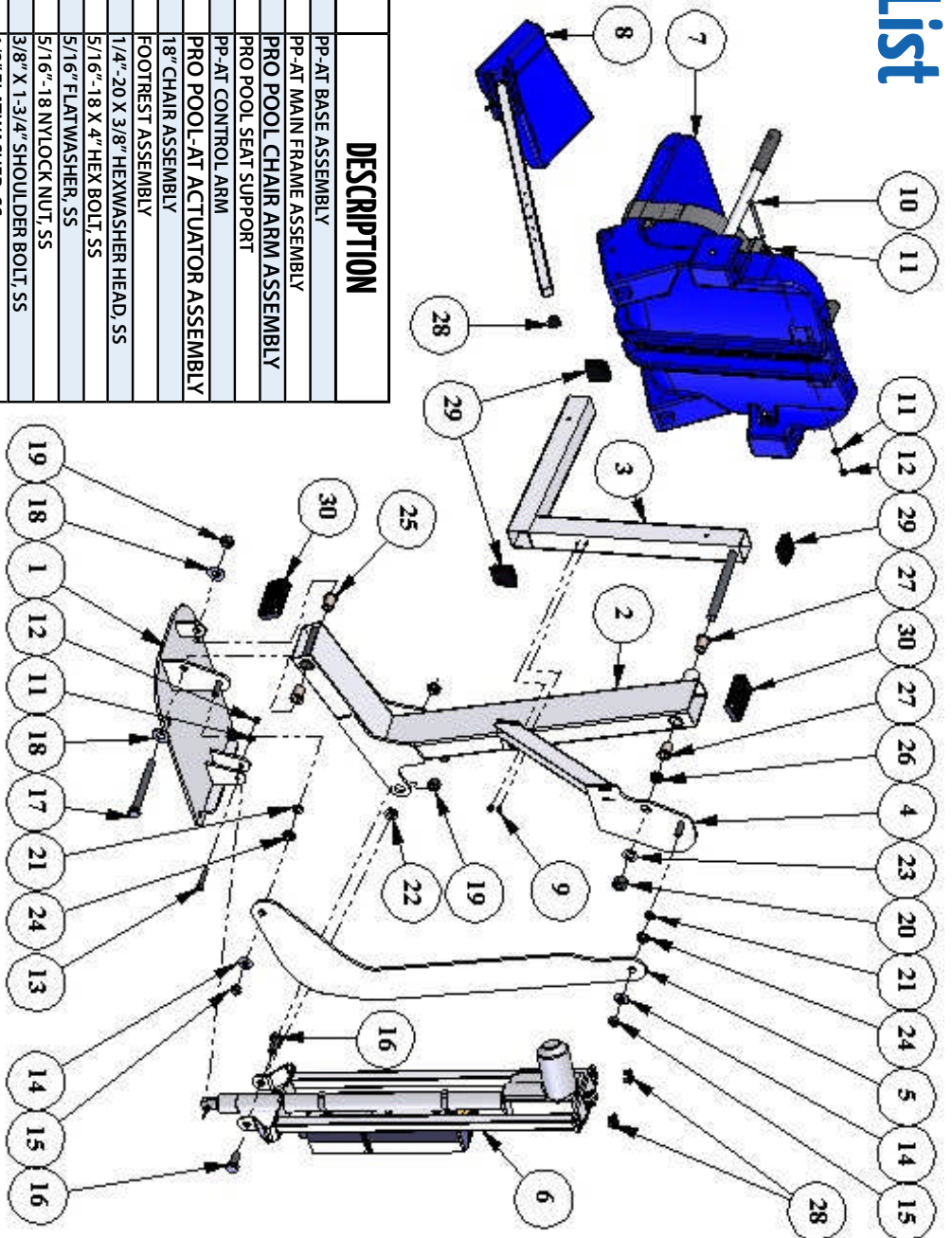

Seat Assembly Parts List

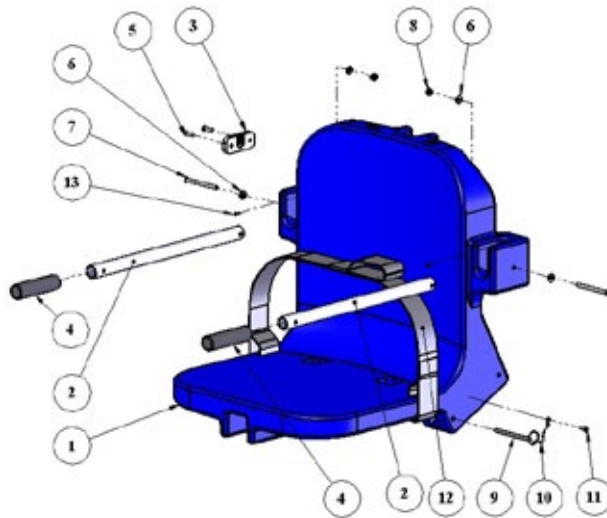

ITEM #	QTY	PART #	DESCRIPTION
1	1	P-901	CHAIR, BLUE ROTOMOLDED (18" WIDE)
2	2	P-2100FLA-38	ARMREST TUBE
3	1	P-1208HSB	HANDSET BRACKET, HDPE
4	2	RUBBER HAND GRIPS	RUBBER HAND GRIPS, BLACK
5	2	SCREW, #12 X 3/4 FHSMS	#12 X 3/4" FLAT-HD SHEET-METAL SCR SS
6	4	FLAT WASHER, 1/4 SS	1/4" FLAT WASHER, 316 SS
7	2	BOLT, 1/4 X 3 1/4 BHSCS	1/4"-20 X 3-1/4" BUTTON-HD CS, SS
8	2	NYLOCK, 1/4 SS	1/4"-20 NYLOCK NUT, SS
9	1	COTTER PIN, 1/4 X 3 1/4	1/4" X 3-1/4" QUICK-PULL PIN FOR FOOTREST
10	1	LANYARD	SS LANYARD FOR FOOTREST PIN
11	1	SCREW, #10 X 3/4 PHSMS	#10 X 3/4" PAN-HEAD SHEET-METAL SCR, SS
12	1	F-38SB	SEAT BELT, 2" BLACK W/VELCRO FOR PP
13	2	SCREW, #6 X 1/2 PHSMS	#6 X 1/2" PAN-HD SHEET-METAL SCR, SS

Actuator Assembly Parts List

Item #	QTY	PART #	DESCRIPTION
1	1	A-8989PPAF	PRO POOL ACTUATOR FRAME
2	1	340461-00	600mm LINEAR ACTUATOR
3	1	CBJ2001NA001381	1-CHANNEL CONTROL BOX
4	1	MBJ2-01	MOUNTING BRACKET, CB/BATTERY
5	1	M5 X10 LPCS	M5 X 10mm LOW-PRO CAP SCREW
6	1	BAJ100000291	24V BATTERY W/ACP LOGO
7	1	SET SCREW, 1/4 X 3/8	t4"-20 X 3/8" SETSCREW, SS
8	1	BOLT, 3/8 X 1 1/4 SHOULDER	3/8" X 1-1/4" SHOULDER BOLT, SS
9	1	FLAT WASHER, 5/16 SS	5/16" FLAT WASHER, SS
10	1	NYLOCK, 5/16 SS	5/16"-18 NYLOCK NUT, SS
11	2	HOSE CLAMP, 1 3/4. SS	1-3/4" HOSE CLAMP, SS
12	1	FLAT WASHER, #10	#10 FLAT WASHER, SS

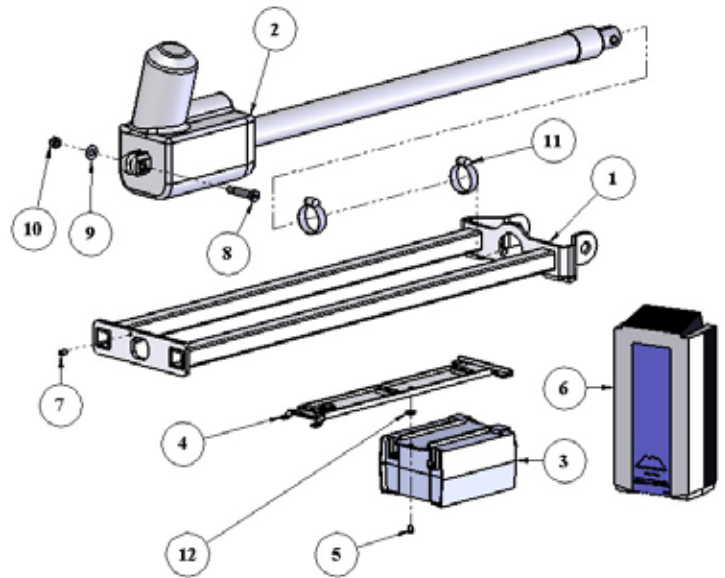

Aqua Creek Products, LLC Limited Lifetime Warranty: **Pro Pool-AT™ Lift**

Aqua Creek Products lifts have a **Limited Lifetime Warranty** on the frames, not including the powder coat finish. Aqua Creek Products, LLC (a.k.a. Aqua Creek) also warrants to the original end user that all non-frame components manufactured by Aqua Creek, when properly installed in accordance with assembly and installation instructions, and properly used and maintained, shall be free from defects in material and workmanship for a period of five (5) years from the date of original purchase, provided that Aqua Creek receives prompt notice in writing of any defect or failure and satisfactory proof thereof, with the following exceptions:

Exception: All electrical components, including the linear actuator shall have the following warranty period:

Year 1-2: 100% Coverage

Year 3: 60% Coverage (Customer is responsible for 40% of replacement cost)

Year 4: 50% Coverage (Customer is responsible for 50% of replacement cost)

Year 5: 40% Coverage (Customer is responsible for 60% of replacement cost)

Hydraulic actuators and mesh slings shall have a warranty period of one (1) year from the date of original purchase.

This warranty specifically excludes reimbursement for labor to remove, repair, or install the product and any return freight charges. These warranties do not cover any damages due to accident, misuse, abuse, negligence or failure to properly maintain any products, or normal wear and tear from day to day operations. In the event that any products are altered, repaired, or improperly installed or improperly used by anyone without the prior written approval by Aqua Creek, all warranties are void. **IMPORTANT: AMOUNT OF WEIGHT PLACED ON LIFT SHALL NOT EXCEED THE RATED LIFTING CAPACITY FOR THE LIFT. NEVER OPERATE THE LIFT UNDER LOAD IN A DRY POOL (WITH WATER IN THE POOL).** It is the responsibility of the lift owner to verify the weight of the patron for warranty claim purposes and to ensure that the lift is not overloaded.

To initiate a warranty claim, the owner of an Aqua Creek product must provide the place of purchase, in writing, with a full description of the product, its serial number, the dates of purchase and installation, and the exact nature of the defect. Within thirty (30) days after receipt of a written warranty claim by Aqua Creek, and barring any unforeseen delays, the place of purchase will be notified of Aqua Creek's decision regarding the claim.

If requested by Aqua Creek, any defective product must be returned, freight prepaid, to Aqua Creek's designated factory location or duly appointed distributor for inspection and/or repair. Aqua Creek will, at its option, repair or replace the failed or defective item, and deliver the repaired product or replacement to the buyer of the product, freight prepaid to the destination provided for in the original order. Products returned to Aqua Creek for which Aqua Creek provides replacement under this limited warranty shall become the property of Aqua Creek. A new warranty period shall NOT be established for the repaired or replaced products. Such products shall remain under warranty only for the remainder of the original warranty period on the original products purchased.

This written limited warranty constitutes the final, complete and exclusive statement of warranty terms. No person or organization is authorized to make any other specific or implied warranties or representations on behalf of Aqua Creek.

THE WARRANTIES SET FORTH HEREIN ARE IN LIEU OF ALL OTHER WARRANTIES, EXPRESSED OR IMPLIED, WHICH ARE HEREBY DISCLAIMED AND EXCLUDED, INCLUDING WITHOUT LIMITATION ANY WARRANTY OF MERCHANTABILITY OR FITNESS FOR A PARTICULAR PURPOSE OR USE.

THE SOLE AND EXCLUSIVE REMEDIES FOR BREACH OF ANY AND ALL WARRANTIES WITH RESPECT TO THE PRODUCTS SHALL BE LIMITED TO REPAIR OR REPLACEMENT AT AQUA CREEK'S DESIGNATED FACTORY LOCATION, OR DULY APPOINTED DISTRIBUTOR, OR IN PLACE AT AQUA CREEK'S OPTION. IN NO EVENT SHALL AQUA CREEK'S LIABILITY EXCEED THE ENTIRE AMOUNT PAID TO AQUA CREEK BY THE ORIGINAL PURCHASER FOR THE FAILED OR DEFECTIVE PRODUCT.

IN NO EVENT SHALL AQUA CREEK PRODUCTS, LLC BE LIABLE FOR ANY INCIDENTAL, CONSEQUENTIAL, SPECIAL, INDIRECT, PUNITIVE OR EXEMPLARY DAMAGES OR LOST PROFITS FROM ANY BREACH OF THIS LIMITED WARRANTY OR OTHERWISE.

THIS WARRANTY GIVES YOU SPECIFIC LEGAL RIGHTS AND YOU MAY ALSO HAVE OTHER RIGHTS, WHICH MAY VARY FROM STATE TO STATE. SOME STATES DO NOT ALLOW THE EXCLUSION OR LIMITATION OF INCIDENTAL, SPECIAL OR CONSEQUENTIAL DAMAGES, SO SOME OF THE ABOVE LIMITATIONS OR EXCLUSIONS MAY NOT APPLY TO YOU.

Aqua Creek Products, LLC
9889 Garrymore Lane
Missoula, MT 59808
Toll Free: (888) 687-3552
Local/Intnl: (406) 549-0769
www.aquacreek.com



Aqua Creek Products

The Total Solution for Pool and Spa Access



F-019CA

Cycle Attachment



F-037XXLS

Sling Seat

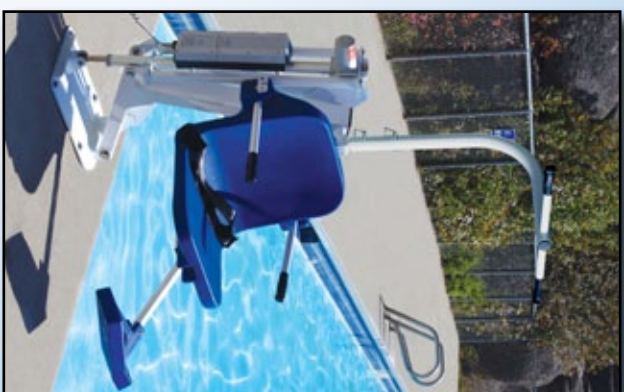

Ranger

with overhead therapy bar

ACCESSORIES & OPTIONS

- F-019CA Cycle Attachment
- F-105LAR Pull-Out Legrest
- F-422PLH Headrest (Pro Pool XR)
- F-422PLH-2 Headrest (All other lifts)
- F-423CS Chest Strap
- F-4140HB Overhead Therapy Bar
- F-705 Wheelchair*
- F-734RSA Spineboard*
- F-736HS Head Immobilizer For Spineboard*
- F-730RSA Gurney*
- F-037XXLS Sling Seat*

*For Revolution Only



F-705

Wheelchair Attachment

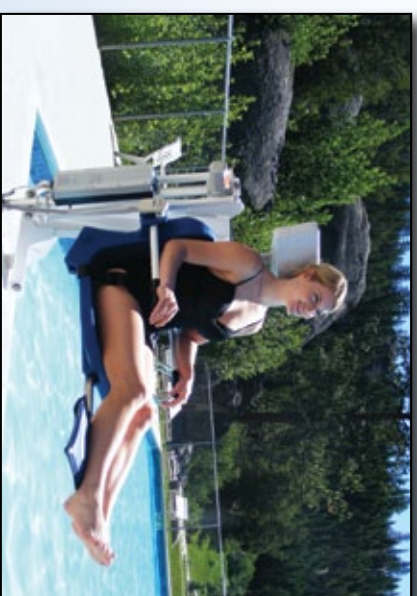

Ranger with headrest and pull-out leg rest options

ACCESSORIES





Aqua Creek Products

The Total Solution for Pool and Spa Access

COVERS

- F-442BL-C Ranger/Pro Pool
- F-12BL-C Pro Pool XR/Pathfinder/Patriot/Portable Pro Pool
- F-450BL-C Scout
- F-720BL-C Revolution/Titan
- F-EZBL-C EZ/Power EZ
- F-440HBC Super Power EZ
- F-440EZHSC EZ/Power EZ
(cover w/hardseat option)
- F-445SLC Spa/Pro Spa 40 Series
- F-460PSLC Pro Spa 60 Series

TRANSPORT CARTS

- F-428HT Ranger/Pro Pool/Pathfinder
- F-914STC Pro Pool XR
- F-814SCTC Scout
- F-714RTC Revolution
- F-614TTC Titan



F-428HT
Transport Cart

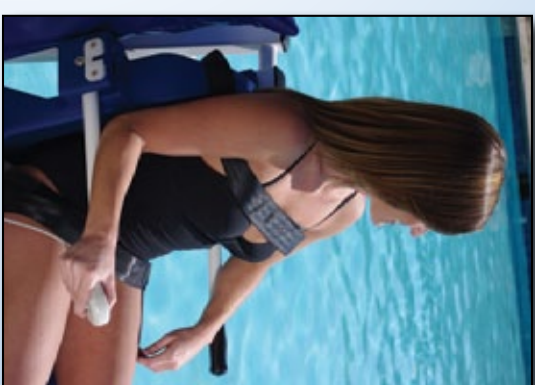

F-423CS
Chest Strap

UPGRADE PACKS

- F-004PLBAP Ranger/Pro Pool + Transport Cart
- F-900PLAP Pathfinder + Transport Cart
- F-920SAP Pro Pool XR + Transport Cart
- F-800SCAP Scout
- F-700RLAP Revolution/Titan
- F-12PPAP Patriot/Portable Pro Pool
- F-03EZPLAP EZ (sliding bars, rigid seat sling w/ seat belt, cover)
- F-03PEZAP Power EZ (sliding bars, rigid seat sling w/ seat belt, cover, extra battery)
- F-190PHBLAP Super Power EZ (sliding bars, rigid seat sling w/seat belt, cover, extra battery)



F-004PLBAP
Upgrade Pack

UPGRADE PACKS INCLUDE**

- Lift Cover
- Extra Battery
- Headrest
- Chest Strap

****For lifts EXCEPT the EZ series. See table for EZ series upgrade pack specifics.**

ACCESSORIES

